

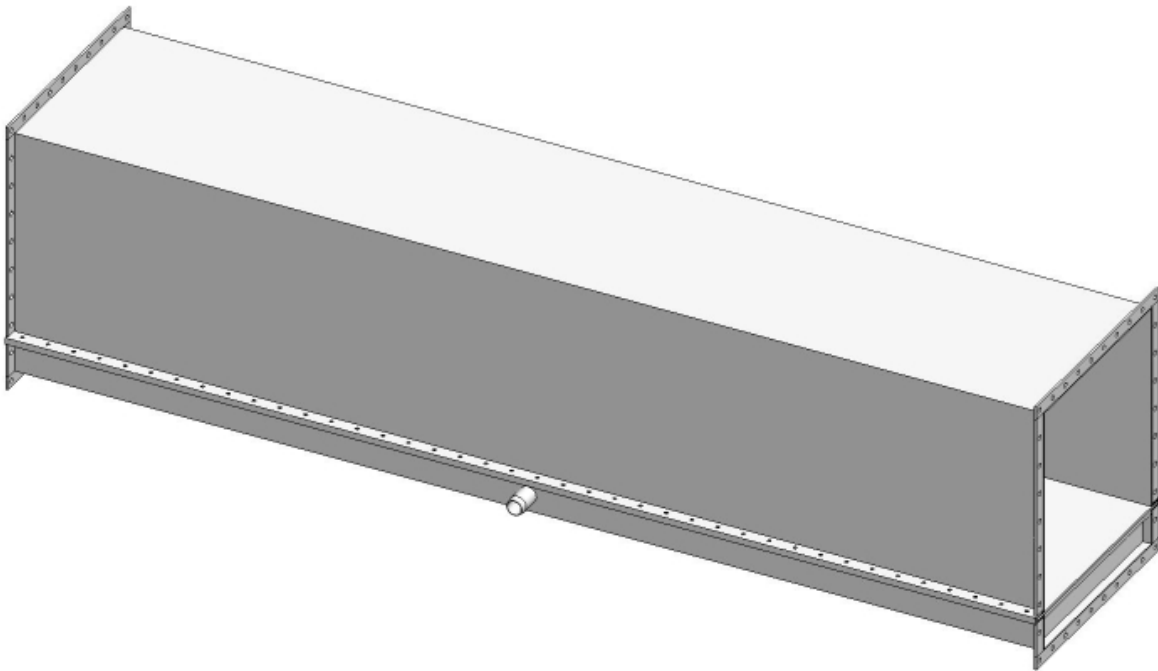

Air Slide Conveyor Systems



W.G. Benjey's air slide conveyor systems will quickly and efficiently convey materials such as raw and finished cement, fly ash, and precipitator dust. The simple combination of air pressure and gravity allows powdered materials to flow like a fluid. Air slide conveyors are very efficient and quiet. And with no moving parts, these conveyors are also extremely cost effective and require very little maintenance.

SPECIFICATIONS AND FEATURES:

Upper and lower bodies are formed from 10 gage steel, with 1/4" steel end flanges. Maximum section length is 12'. Each section is independently pressurized and requires only a single air inlet.

- Flow regulation through air pressure regulation
- Extremely quiet operation
- Low maintenance, no moving parts
- Minimal wear from abrasion
- Low pressure requirements, 0.5—5.0 psi

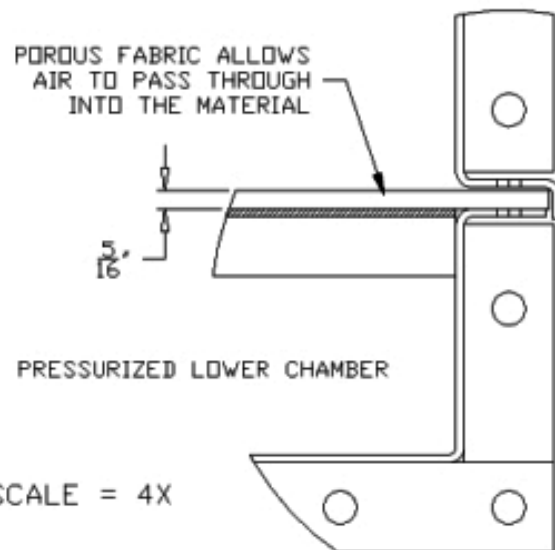
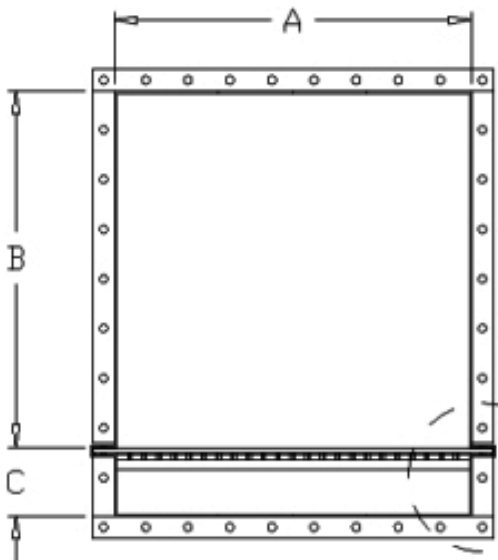
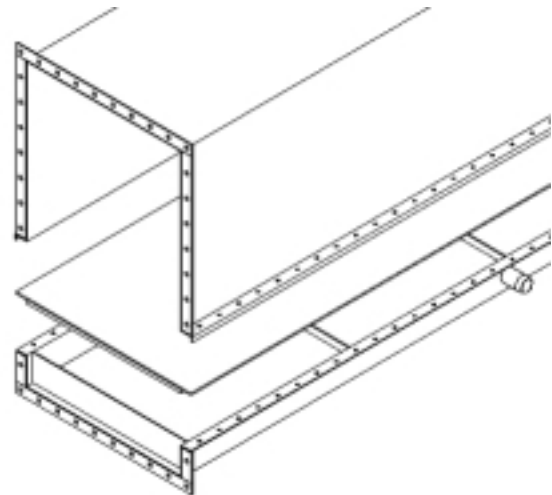

Type	Maximum Capacity	"A" (in.)	"B" (in.)	"C" (in.)
WGB-AS6	1200 cu.ft./hr.	6	7-7/8	4-5/8
WGB-AS12	7620 cu.ft./hr.	12	15-3/4	4-5/8
WGB-AS24	56000 cu.ft./hr.	24	23-5/8	4-5/8



2293 WERTH ROAD
 ALPENA, MI 49707
 PHONE: (989) 356-1433
 FAX: (989) 356-6446

SYSTEM DESIGN:

Air slide conveyors can be used in a single straight run, but are equally as effective when used in large systems. Through the use of turn boxes, conveyors can easily change directions, merge, or split without the need for powered conveyors or diverters. Manual or powered shut off gates can be integrated into any point of the system to control flow.

The maximum range of the conveyors are limited only by the height of the source. Conveyors require a minimum of a 5 degree drop angle to function properly. A 10 degree angle is recommended for most applications.

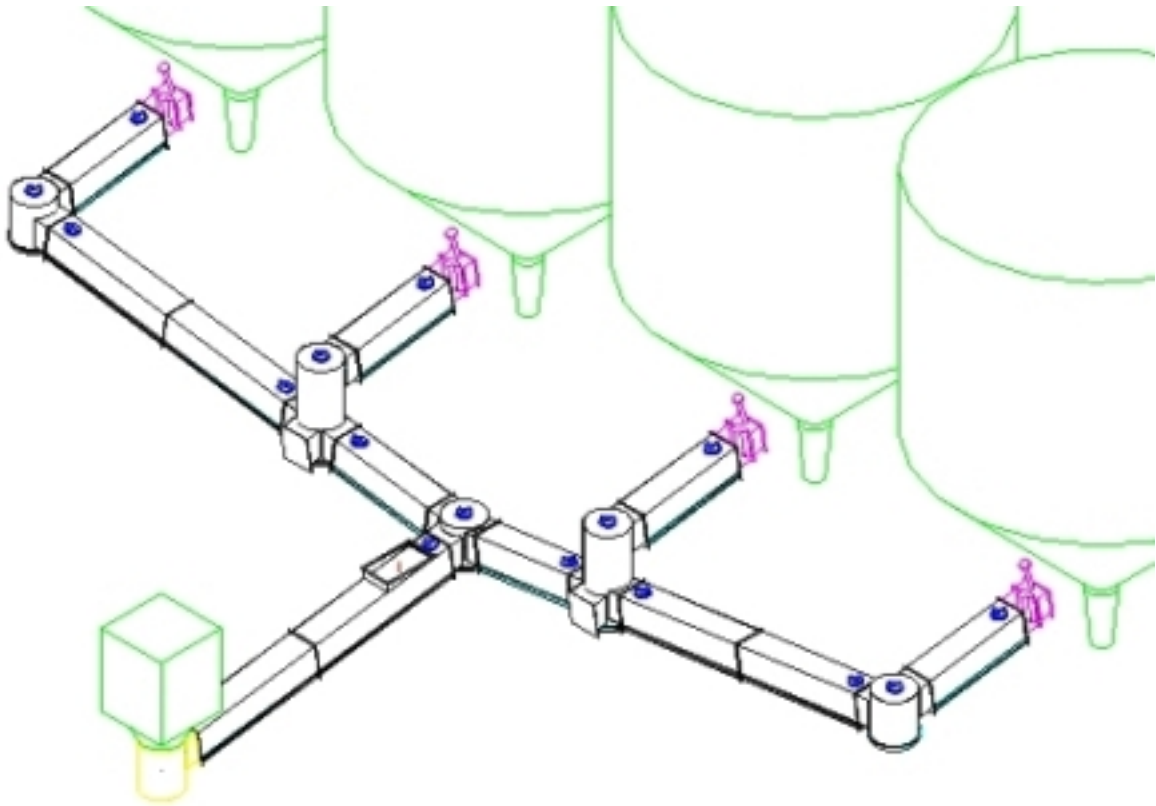
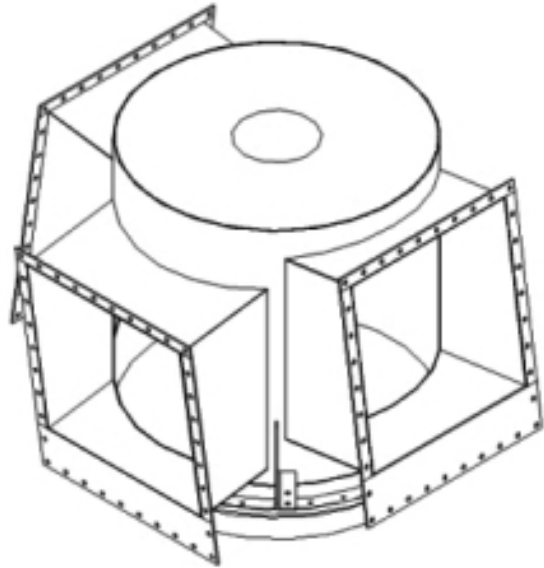

Air slide conveyors also utilize traditional conveyor components such as diverter gates, flow controls, shut-off gates, and discharge chutes. Air slide technology can also be applied to your existing or newly manufactured storage bins.



2293 WERTH ROAD
ALPENA, MI 49707
PHONE: (989) 356-1433
FAX: (989) 356-6446